

NOTES:

1. LUMINAIRE # 8367P – SEE SPECIFICATIONS.
2. (1) 27W ELECTRONIC FLUORESCENT UNIVERSAL 120–277V BALLAST PROVIDED INSIDE LUMINAIRE.
3. (2) 27W CF TWIN 4–PIN LAMPS (PROVIDED BY OTHERS).
4. AVAILABLE IN STANDARD BEGA COLORS.

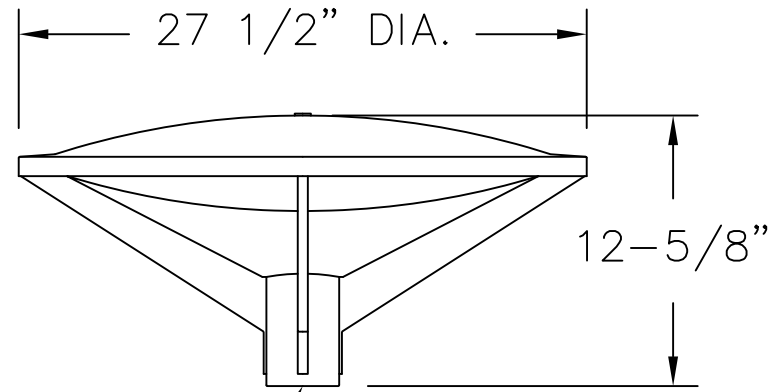

SLIP FITS 3" O.D.  
POLE OR TENON  
(REQUIRES A MINIMUM 3" LENGTH OF  
STRAIGHT DIA. POLE/TENON)

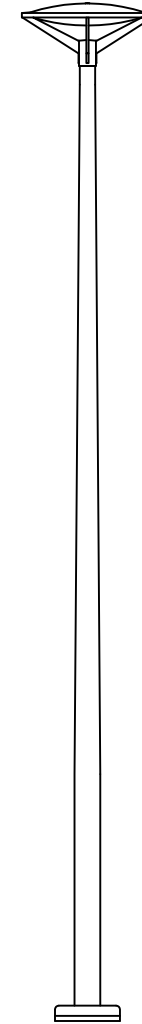

SHOWN ON 1508HR

Catalog No.: 8367P

Description: POLE TOP - SHIELDED LIGHT SOURCE

Drawn by: ES Date: 9/9/08 File Name: 8367P

SCALE: NONE – DO NOT SCALE DRAWING

This print contains confidential information which is the property of BEGA/US. By accepting this information, the borrower agrees that it will not be used for any other purpose other than that which is was loaned.

**BEGA**

1000 Bega Way  
Carpinteria, Ca. 93013  
(805) 684-0533

## Pole top luminaires with widespread distribution

**Housing/fitter:** Lower slip fitter is made from a single die-cast aluminum part which includes four support arms and the lower diffuser frame. The fixture slip fits a 3" O.D. pole top or tenon and is secured by four stainless steel set screws. The top portion of the lamp housing is made from heavy gauge spun aluminum. Relamping is achieved by removing a single threaded fastener at the top of the fixture.

**Enclosure:** Molded 1/4" white high impact acrylic lens. Completely sealed with a high temperature silicone gasket for weather tight operation.

**Electrical:** Lampholders are type 2G11. Ballasts are located inside the luminaire head and are electronic, universal voltage (120V through 277V), program start with a minimum start temperature of 0°F.

**Finish:** Available in four standard BEGA colors: Black (BLK); White (WHT); Bronze (BRZ); Silver (SLV). To specify, add appropriate suffix to catalog number. Custom colors supplied on special order.

**UL listed,** suitable for wet locations. Protection class: IP65.

**Weight:** 26 lbs.

**Effective Projection Area (EPA):** 1.0 ft<sup>2</sup>

Type:  
 BEGA Product:  
 Project:  
 Voltage:  
 Color:  
 Options:  
 Modified:

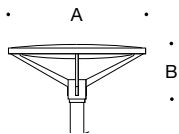

	Lamp	Lumen	A	B
<b>8367 P</b>	2 27W CF twin-4p	3600	27½	12⅝

**BEGA-US** 1000 BEGA Way, Carpinteria, CA 93013 (805) 684-0533 FAX (805) 566-9474 [www.bega-us.com](http://www.bega-us.com)

©copyright BEGA-US 2012 Updated 8/12