

Sumac Circle and Cedarwood Lane Improvements Special Service Area #107

Welcome!

Design Open House
October 16th, 2023
6:45 PM



Project Background: Sumac Circle and Cedarwood Lane

- Last Resurfaced – 2001
- In 2020, petition submitted by residents for curb installation
- In 2021, Village balloted properties for curb installation
 - 17/24 votes were received in support for curb installation on Sumac/Cedarwood (24 Properties)
- Construction Year: 2024

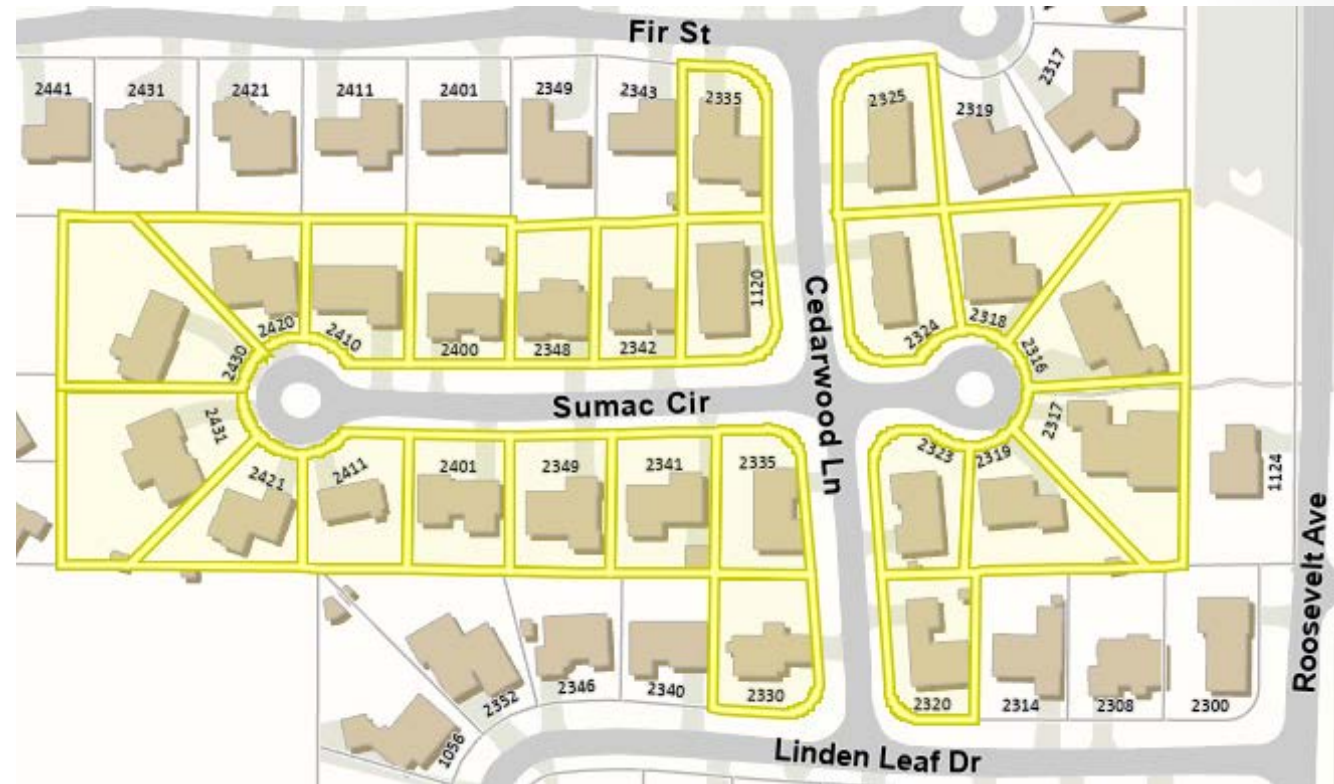

Project Location and Limits

- Cedarwood Lane: From Linden Leaf Drive to Fir Street (approximately 600 feet)
- Sumac Circle: West Cul-De-Sac to East Cul-De-Sac (approximately 800 feet)
- All work to be completed within the public right-of-way
- Construction year: 2024

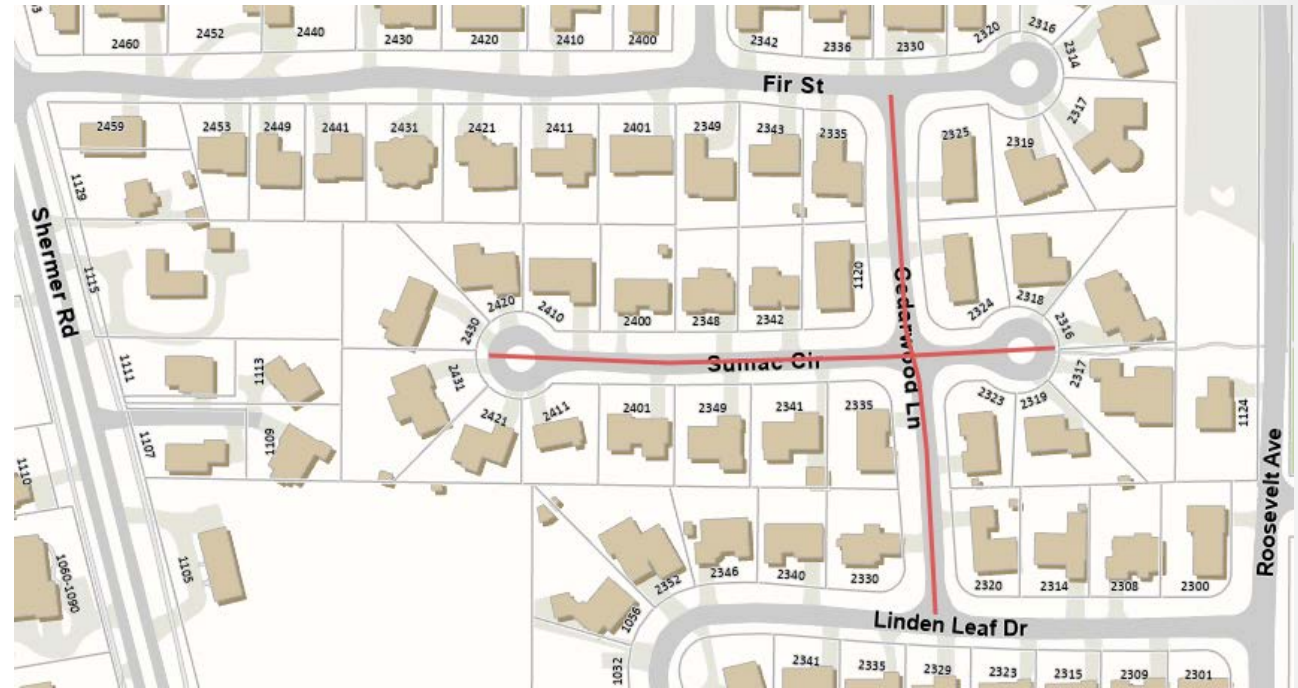

Scope of Work and Benefit to Residents

- Replacement of existing **water main** with new **8-inch diameter water main**, including new **1 ½ -inch water services and new b-boxes**
- Extend **storm sewer system to cul-de-sacs** and install additional inlets.
- **Sanitary service** replacements
- Roadway reconstruction with **new asphalt pavement** including **new curb and gutter** through SSA
- **Driveway apron** replacement (in-kind)
- **Parkway restoration** with sod

Existing and Proposed Typical Plans: Sumac Circle

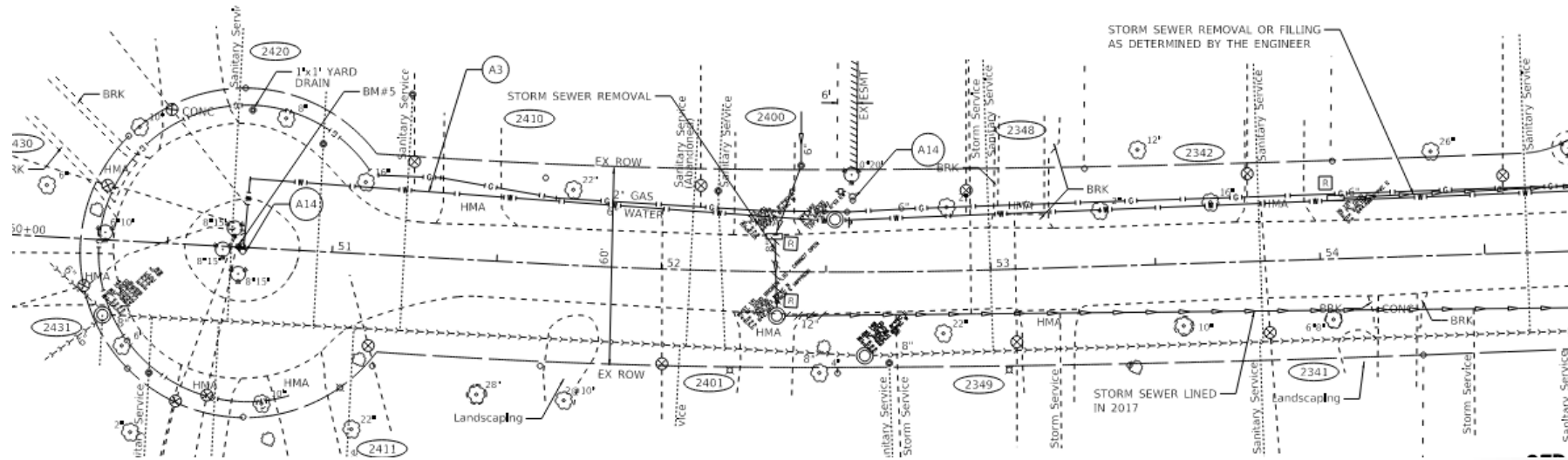

**EXISTING PLAN
SUMAC CIRCLE**

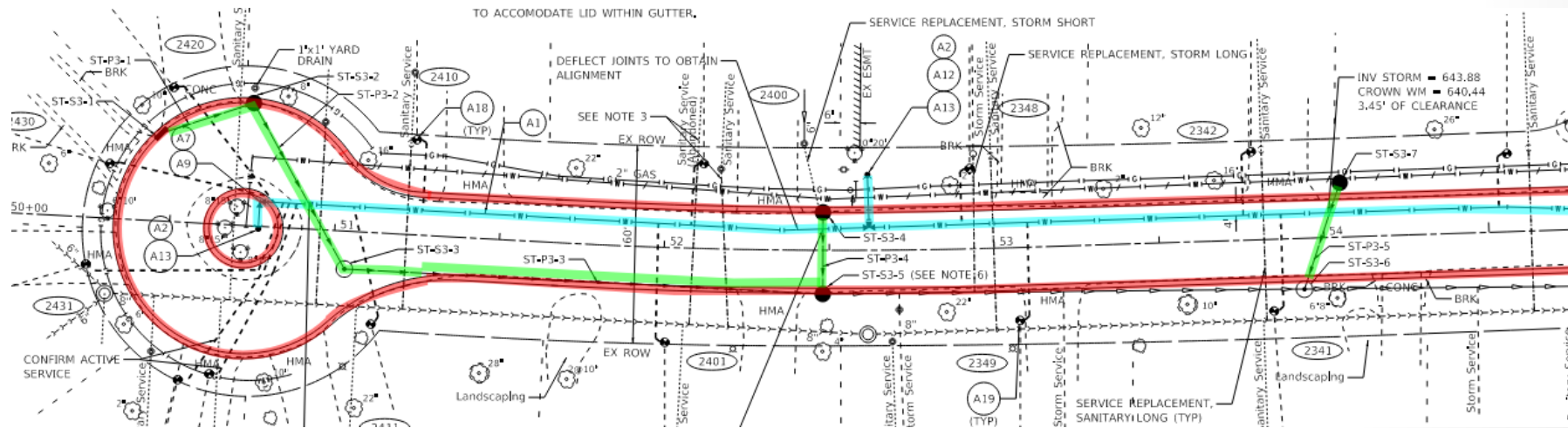

**PROPOSED PLAN
SUMAC CIRCLE**

New
Storm
Sewer

New
Water
Main

New
Curb &
Gutter

Existing and Proposed Typical Section

EXISTING LEGEND

- (A) HMA PAVEMENT (SEE NOTE 1)
- (B) AGGREGATE BASE (10")
- (C) CLAY SUBGRADE
- (D) DRIVEWAY
- (E) SIDEWALK
- (F) GROUND SURFACE
- (G) PAVEMENT REMOVAL (SPECIAL) - 7"
- (H) DRIVEWAY REMOVAL (INCLUDED IN DRIVEWAY REMOVAL AND REPLACEMENT) *
- (I) SIDEWALK REMOVAL (INCLUDED IN SIDEWALK REMOVAL AND REPLACEMENT) *
- [Hatched Box] ITEM TO BE REMOVED

PROPOSED LEGEND

- (1) HOT-MIX ASPHALT SURFACE COURSE, MIX "D", N50 - 2"
- (2) HOT-MIX ASPHALT BINDER COURSE, IL-19.0, N50 - 5"
- (3) CONCRETE CURB AND GUTTER CONSTRUCTION, TYPE M-3,12 (10" MIN GUTTER FLAG DEPTH; DEPRESSED AT DRIVEWAYS)
- (4) AGGREGATE BASE COURSE REMOVAL AND REPLACEMENT, 6"
- (5) GEOTECHNICAL FABRIC FOR GROUND STABILIZATION *
- (6) REMOVAL AND DISPOSAL OF UNSUITABLE MATERIAL; AND AGGREGATE SUBGRADE IMPROVEMENT (6" MIN) (SEE NOTE 4) *
- (7A) CONCRETE DRIVEWAY REMOVAL AND REPLACEMENT *
- (7B) HOT-MIX ASPHALT DRIVEWAY REMOVAL AND REPLACEMENT *
- (7C) BRICK PAVER REMOVAL AND STOCKPILING (SPECIAL) *
- (8) TOPSOIL, FURNISH AND PLACE 4"; AND SODDING *
- (9) CONCRETE SIDEWALK REMOVAL AND REPLACEMENT OR SIDEWALK CONSTRUCTION (5", THICKEN TO 6" AT DRIVEWAYS)
- (10) PREPARATION OF BASE

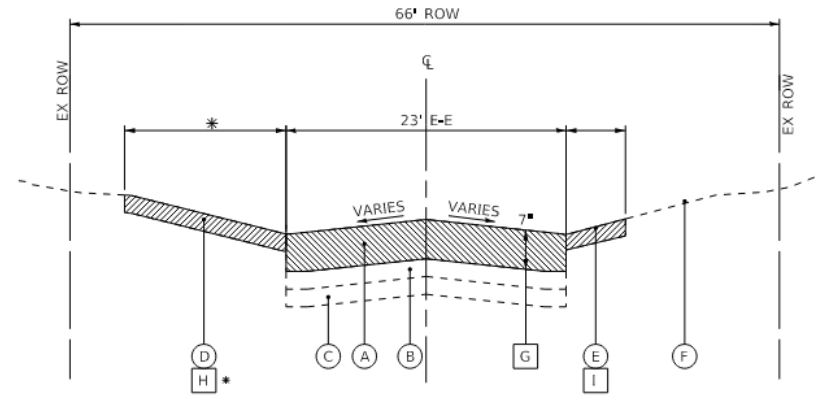

PROPOSED TYPICAL SECTION
CEDARWOOD LANE
SUMAC CIRCLE

NOT TO SCALE

* AS DETERMINED BY ENGINEER

CL SEE PLANS FOR LOCATIONS OF EXISTING SIDEWALK

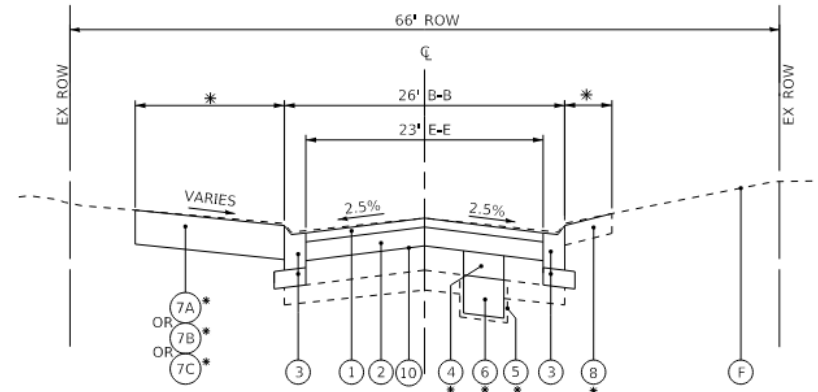

PROPOSED TYPICAL SECTION
CEDARWOOD LANE
SUMAC CIRCLE

NOT TO SCALE

* AS DETERMINED BY ENGINEER

Estimated Project Costs

TOTAL Project Cost - \$1,297,000

Storm Sewer – \$252,000

Water Main Replacement – \$398,000

Sanitary Sewer – \$70,000

Pavement and Parkway Restoration – \$478,000

Curb & Gutter – \$99,000

- **Resident estimated cost-shared amounts**
 - **Curb & Gutter SSA 107 (distributed amongst 24 properties) = \$102,800**
 - * **Resident share includes 4% contingency**

Note: These costs are estimates. Actual costs will be based on the lowest bid and the loan interest rate. SSA payments are calculated based on the Equalized Assessed Values for each property and redistribute by Cook County on the annual basis through the property tax bill

Sample Resident
Cost (20 year term)
6% interest rate

Estimated

Sumac-Cedarwood Improvement Project

Estimated SSA Projects Costs

Project Scope Includes Curb and Gutter

Homeowner Costs
50% of curb and gutter related items \$ 102,800.00 (including 4% contingency)
TOTAL HOMEOWNER SSA COSTS \$ 102,800.00
Finance Calculations-
SSA Interest Rate % 6
Number of payments per year 2
Repayment term (years) 20
Total number of lots 24

SSA Finance Payment-	
Total Homeowner's	Total Homeowner's
Semi-Annual Payment	Annual Payment
\$4,447.37	\$ 8,894.74

Average Cost Per Home Per Year
\$370.61

Property Specific Estimated Project Cost-

# Of Homes	PIN #	Property Address	Cook County Assessor Equalized Assessed Valuation (2021 values)	PIN % of Total AV	Improvement Cost For Each Property	Estimated Semi-Annual Payment (20 year term)	Estimated Annual Payment (20 year term)
1	04-34-202-087-0000	2411 Sumac Cir	129,981.00	3.69%	3,795.76	164.21	328.43
2	04-34-202-031-0000	2316 Sumac Cir	139,547.00	3.96%	4,075.11	176.30	352.60
3	04-34-202-043-0000	2342 Sumac Cir	133,020.00	3.78%	3,884.51	168.05	336.11
4	04-34-202-083-0000	2410 Sumac Cir	139,247.00	3.96%	4,066.35	175.92	351.84
5	04-34-202-028-0000	2325 Fir St	127,176.00	3.61%	3,713.85	160.67	321.34
6	04-34-202-047-0000	2335 Sumac Cir	137,506.00	3.91%	4,015.51	173.72	347.44
7	04-34-202-048-0000	2330 Linden Leaf Dr	119,438.00	3.39%	3,487.88	150.89	301.79
8	04-34-202-081-0000	2430 Sumac Cir	257,902.00	7.33%	7,531.36	325.82	651.65
9	04-34-202-045-0000	2349 Sumac Cir	189,816.00	5.39%	5,543.09	239.81	479.61
10	04-34-202-034-0000	2323 Sumac Cir	122,798.00	3.49%	3,586.00	155.14	310.28
11	04-34-202-029-0000	2324 Sumac Cir	115,796.00	3.29%	3,381.52	146.29	292.59
12	04-34-202-035-0000	2320 Linden Leaf Dr	130,623.00	3.71%	3,814.51	165.02	330.05
13	04-34-202-084-0000	2400 Sumac Cir	220,281.00	6.26%	6,432.74	278.30	556.59
14	04-34-202-044-0000	2348 Sumac Cir	118,811.00	3.38%	3,469.57	150.10	300.20
15	04-34-202-088-0000	2401 Sumac Cir	132,323.00	3.76%	3,864.15	167.17	334.34
16	04-34-202-032-0000	2317 Sumac Cir	195,728.00	5.56%	5,715.73	247.28	494.55
17	04-34-202-042-0000	1120 Cedarwood Ln	136,260.00	3.87%	3,979.12	172.15	344.29
18	04-34-202-041-0000	2335 Fir St	123,600.00	3.51%	3,609.42	156.15	312.30
19	04-34-202-085-0000	2431 Sumac Cir	158,092.00	4.49%	4,616.67	199.73	399.46
20	04-34-202-046-0000	2341 Sumac Cir	164,374.00	4.67%	4,800.12	207.66	415.33
21	04-34-202-033-0000	2319 Sumac Cir	134,704.00	3.83%	3,933.68	170.18	340.36
22	04-34-202-086-0000	2421 Sumac Cir	123,234.00	3.50%	3,598.73	155.69	311.38
23	04-34-202-030-0000	2318 Sumac Cir	136,344.00	3.87%	3,981.57	172.25	344.50
24	04-34-202-082-0000	2420 Sumac Cir	133,656.00	3.80%	3,903.08	168.86	337.71
		TOTALS	\$ 3,520,257.00	100.00%	\$ 102,800.00	\$ 4,447.37	\$ 8,894.74

Note: These costs are estimated and shown for reference only. Actual resident costs will be administrated by Cook County based on Equalized Assessed Value (EAV)

Tentative Schedule and Next Steps

Dates	Steps
October 16, 2023	Design Open House Meeting (Today)
November 7, 2023	First consideration of an ordinance proposing the establishment of SSA
November 21, 2023	Second consideration of an ordinance proposing the establishment of SSA 107
December 11, 2023	Notice to be sent to newspaper regarding public hearing
December 21 , 2023	Public Notice – notice of Public Hearing for SSAs
December 21, 2023	Certified mail sent to area residents regarding Public Hearing
January 9, 2024	Public Hearing (start of 60-day period)
January 9, 2024	First consideration of an ordinance establishing SSA 107
January 23, 2024	Second consideration of an ordinance establishing SSA 107
March 11, 2024	End of 60 day waiting period & ordinance effective date
February/March 2024	Contract Award
March/April 2024	Pre-construction meeting with residents
April 2024	Start of construction
July/August 2024	Anticipated Construction Completion Date

Resident's FAQ's

If my driveway is damaged, will it be fixed or replaced?

- Sections of private driveways located in the public right-of-way will be replaced if damaged during construction with the exception of edging materials and brick paver driveways. Reimbursement is available for reinstallation of brick pavers with the driveway apron located in the public right-of-way or brick paver driveway aprons can be replaced with concrete or asphalt aprons as part of the project.

Will my driveway be closed during construction?

- Private drives will be accessible the majority of the time during construction. If your driveway needs to be closed, notice will be provided to allow adequate time to make arrangements.

Will the parkway be restored after construction is completed?

- Parkway areas disturbed by construction will be restored with sod during the last stage of construction. Please note that residents are responsible for the removal of private items located within the public parkway such as landscaping features, fencing, boulders, sprinklers, planters, etc. These items will not be replaced if damaged.

Will garbage pick up or bus pickup & drop off be impacted?

- The garbage service in your neighborhood will not be impacted during construction.
- Before bus routes are impacted, the school, bus company, and residents will be notified in advance of any alternate bus pick up and drop off.

Project Updates

1. Navigate to <https://www.glenview.il.us/Pages/Default.aspx>

2. Select Traffic & Transportation > Construction Projects

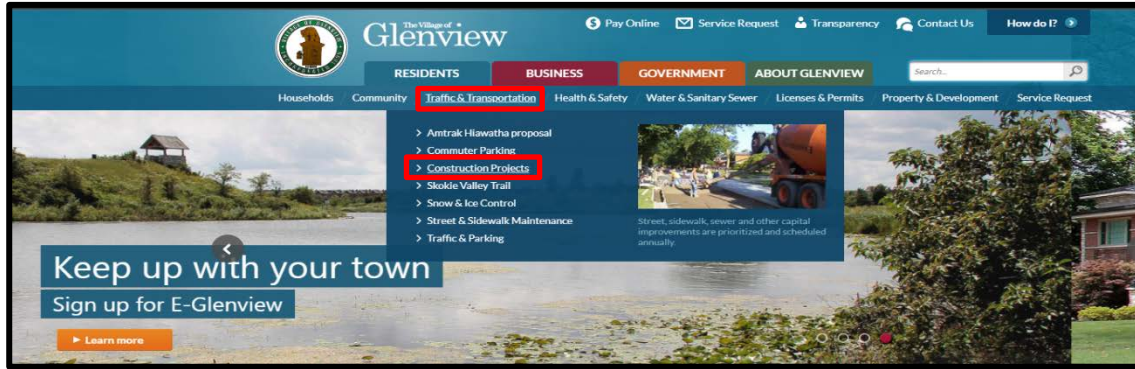

3. Scroll down to 2024 Public Improvements Project List and select Sumac Circle & Cedarwood Lane Improvements

4. Scroll down to Notification Signup and enter your information

- Project Website Information and updates will be available during pre-construction resident meeting
- Sign up to receive weekly updates at the link listed above
- Keep your eyes open for hand-delivered letters and door hangers throughout the project

Project Updates

Find all [project updates here](#).

To sign up for future notifications on this project, fill out the form below. We will email updates on this project when they are available.

First Name	<input type="text"/>
Last Name	<input type="text"/>
Email Address	<input type="text"/>
Confirm Email Address	<input type="text"/>
Street Number	<input type="text"/>
Street Name	<input type="text"/>
Phone number	<input type="text"/>
<input type="submit" value="Submit"/>	

Please click the submit button once. Submission time is based on connection speed. This form will update to confirm your information was submitted.

Contact Us

Construction Project Managers

Tom Hagerty

Email: thagerty@glenview.il.us

Phone: (847) 904-4421

Tim Schwister

Email: tschwister@glenview.il.us

Phone: (847) 904-4422

Engineering Division Manager

Adriana Webb

Email: awebb@glenview.il.us

Phone: (847) 904-4414

If you consider doing work on your private property, a permit is required for:

- New driveway
- Private storm sewer drain and connection to public sewer

Get more information here:

<https://www.glenview.il.us/Pages/Building-Permits.aspx>